

Form 18753  
March, 1935  
PRINTED IN U.S.A.

**ADJUSTERS MANUAL**  
FOR  
**SINGER PORTABLE MACHINE**  
**221-1**

LOCK STITCH, FOR FAMILY USE  
WITH SERIES 3 MOTOR  
AND FOOT CONTROLLER

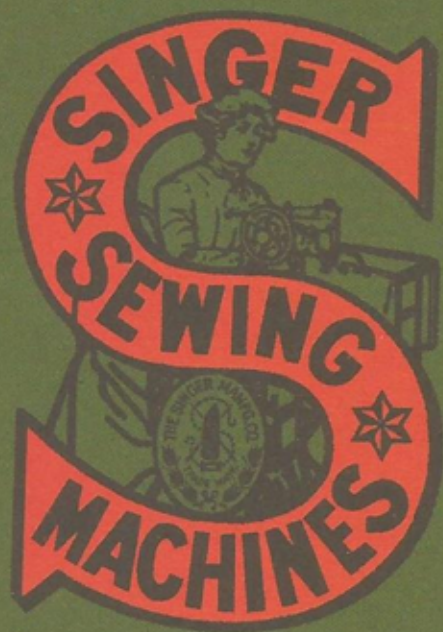

**THE SINGER MANUFACTURING CO.**

Copyright, U.S.A., 1921, 1922, 1930, 1931, 1932, 1933 and 1935, by The Singer Manufacturing Co.  
All Rights Reserved for all Countries

### To Pack Machine and Attachments

When placing the machine in its carrying case, have the balance wheel at the right hand side of the case and see that the base of the machine is at the right of the cleat at the bottom of the case.



CARRYING CASE

Henceforth the attachments for Machine 221-1 will be shipped, from the factory, in a collapsible cardboard box. Singer Shops will transfer the attachments to the carrying case tray and arrange them in the manner indicated by the above illustration.



ADJUSTERS MANUAL  
FOR  
SINGER PORTABLE MACHINE  
221-1

LOCK STITCH, FOR FAMILY USE  
WITH SERIES 3 MOTOR  
AND FOOT CONTROLLER

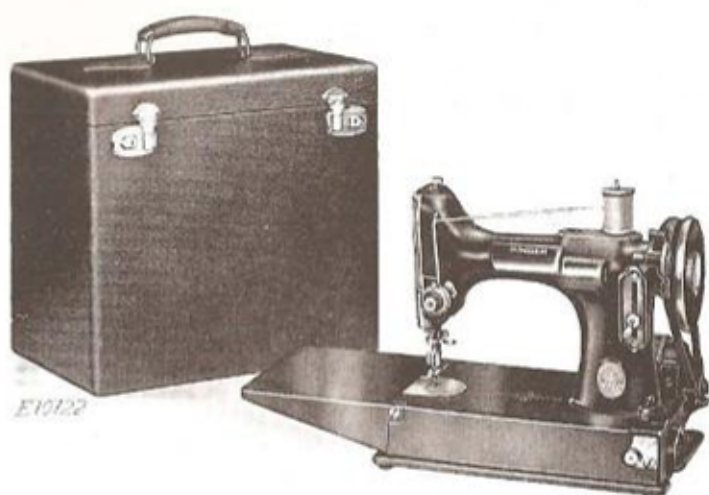

MACHINE 221-1 COMPLETE WITH CARRYING CASE

To all whom it may concern:

The placing or renewal of the name "Singer" (Reg. U. S. Pat. Off.) or any of the trade marks of The Singer Manufacturing Company on any machine that has been repaired, rebuilt, reconditioned or altered in any way whatsoever outside a Singer factory or an authorized Singer agency, is forbidden.

---

THE SINGER MANUFACTURING CO.

# INDEX

---

|   | PAGE   |
|---|--------|
| ARM SHAFT   |        |
| To ADJUST ARM SHAFT END PLAY.....                       | 30     |
| BELT  |        |
| To ADJUST BELT TENSION.....                             | 19     |
| BOBBIN WINDER   |        |
| To ADJUST THE BOBBIN WINDER.....                        | 28     |
| To ADJUST BOBBIN WINDER TENSION BRACKET.....            | 28     |
| CONTROLLER  |        |
| DESCRIPTION AND ADJUSTMENT OF FOOT CONTROLLER.....      | 12-14  |
| ELECTRICAL CONNECTIONS                                  |        |
| INSPECTION OF ELECTRICAL CONNECTIONS.....               | 8-14   |
| WIRING DIAGRAMS.....                                    | 4, 5   |
| FEEDING MECHANISM                                       |        |
| To ADJUST FEED DOG IN THROAT PLATE SLOTS.....           | 27     |
| To RAISE AND LOWER FEED DOG.....                        | 27     |
| HINGED BED EXTENSION                                    |        |
| To REMOVE AND REPLACE HINGED BED EXTENSION.....         | 20     |
| LUBRICATION   |        |
| To LUBRICATE MACHINE.....                               | 31, 32 |
| To LUBRICATE MOTOR.....                                 | 19     |
| MOTOR   |        |
| CIRCUITS ON WHICH SERIES 3 MOTOR CAN BE OPERATED.....   | 3      |
| CAUSES OF TROUBLE.....                                  | 6, 7   |
| To REMOVE MOTOR FROM MACHINE.....                       | 15     |
| To DISASSEMBLE MOTOR.....                               | 16-18  |
| To REASSEMBLE AND REPLACE MOTOR.....                    | 18, 19 |
| SINGERLIGHT   |        |
| SINGERLIGHT AND SINGERLIGHT SWITCH CONNECTIONS.....     | 8-11   |
| SINGERLIGHT FAILS TO LIGHT.....                         | 11     |
| To REMOVE AND REPLACE BULB.....                         | 11     |
| STITCHING MECHANISM                                     |        |
| To ADJUST CLEARANCE BETWEEN ROTARY HOOK AND NEEDLE..... | 26, 27 |
| To REMOVE AND REPLACE ROTARY SEWING HOOK.....           | 22, 23 |
| NEW ROTARY SEWING HOOK.....                             | 25, 26 |
| To REMOVE AND REPLACE ROTARY SEWING HOOK SHAFT.....     | 23-25  |
| NEW ROTARY SEWING HOOK SHAFT.....                       | 25, 26 |
| To SET NEEDLE BAR AT CORRECT HEIGHT.....                | 22     |
| To TIME ROTARY SEWING HOOK.....                         | 21     |
| THREAD CONTROLLING MECHANISM                            |        |
| To REGULATE THREAD TAKE-UP SPRING.....                  | 29     |
| To ADJUST TENSION OF THREAD TAKE-UP SPRING.....         | 29     |
| THROAT PLATE  |        |
| To REMOVE AND REPLACE THROAT PLATE.....                 | 20     |



### Singer Series 3 Motors

The Series 3 Motors, for use with Machine 221-1, are operated on either alternating current or direct current, but the motor **rating** must be selected to correspond to the electric current available. Therefore, before connecting the motor to the electric service line, take a copy of the data stamped on the motor name plate and check it with your local Electric Company to make sure that the volts and cycles agree.

Carefully observe the above instructions when selecting the motor from the following list:

| VOLTS   | CURRENT   | MOTOR CATALOG NO. |
|---------|---|-------------------|
| 32      | Direct Current Only   | 3-32              |
| 50      | Direct Current<br>and<br>25 to 75 Cycles<br>Alternating Current | 3-50              |
| 95-100  |   | 3-100             |
| 100-110 |   | 3-110             |
| 115-125 |   | 3-125             |
| 130-145 |   | 3-145             |
| 150-165 |   | 3-165             |
| 200-220 |   | 3-220             |
| 210-230 |   | 3-230             |
| 230-250 | 3-250   |                   |
| 100-110 | 80 to 100 Cycles<br>Alternating Current                         | 3-118             |
| 200-220 |   | 3-228             |
| 230-250 |   | 3-258             |

Only rarely is a supply of electricity found where none of the above listed motors is suitable. In such a case, the factory should be consulted regarding the possibility of supplying a special motor.

#### To Ensure Correct Demonstration of Machine

Be sure that the voltage range, specified on the name plate of the motor, is within the range of voltage of the electric service line. A **higher service line voltage will produce excessive speed and will cause damage to the motor, while a lower voltage will cause the motor to operate too slowly.**

## Electrical Connections for Machine 221-1 and Series 3 Motor

To facilitate the proper connection of the leads to the terminals, the two outer connection pins, Nos. 1 and 3, are distinguished by a yellow and red spot, respectively, directly above the pins. The middle pin, No. 2, is uncolored. The leads for these pins have tracer threads of corresponding colors running through them. The solid black lead is for attachment to the middle, uncolored pin No. 2.

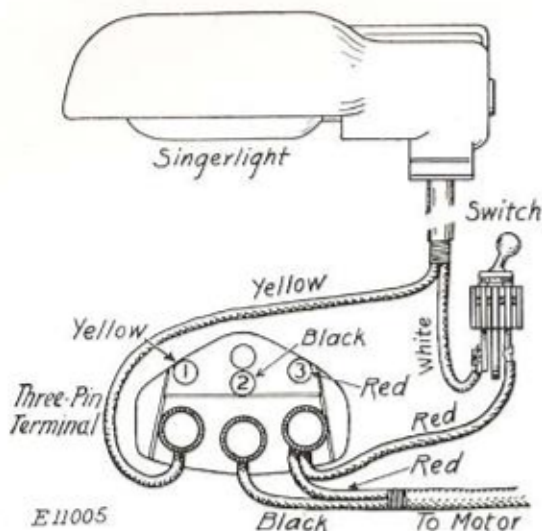

FIG. 2. THREE-PIN TERMINAL AND SINGERLIGHT WIRING DIAGRAM

tinguished by a yellow and red spot, respectively, directly above the pins. The middle pin, No. 2, is uncolored. The leads for these pins have tracer threads of corresponding colors running through them. The solid black lead is for attachment to the middle, uncolored pin No. 2.

The connections are made as follows:

**Motor Leads**—Fasten the lead with the **red** tracer thread to the **red** pin, No. 3, and fasten the solid **black** motor lead to the **middle** pin, No. 2, as illustrated in Fig. 2.

**Singerlight Leads**—Fasten the lead with the **yellow** tracer thread to the **yellow** pin, No. 1, and fasten the lead with the **red** tracer thread to the **red** pin, No. 3. This red lead connects terminal and Singerlight switch. A white wire connects Singerlight switch and Singerlight, as shown in Fig. 2.



The lead cord is provided with a plug for the electric outlet, and the plug for the three-pin terminal. The plug for the three-

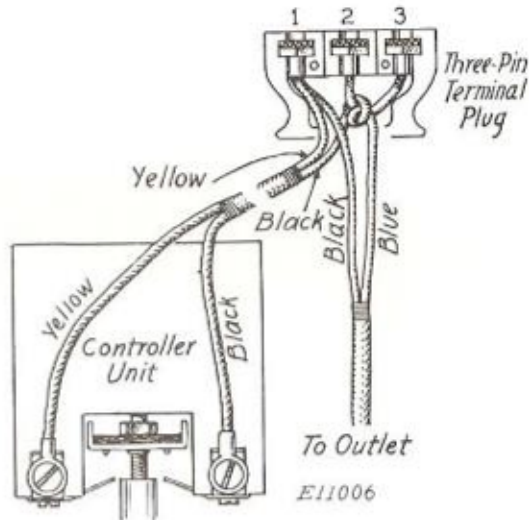

FIG. 3. THREE-PIN TERMINAL PLUG AND FOOT CONTROLLER WIRING DIAGRAM

pin terminal is marked with the numerals 1, 2 and 3, to correspond with the pin numbers of the three-pin terminal.

Connections are made as follows:

**Controller Leads**—Fasten the lead with the **yellow** tracer thread to terminal No. 1 and fasten the solid **black** lead to terminal No. 2, as indicated by Fig. 3, Wiring Diagram.

**Electric Service Leads**—Fasten the **black** wire to connection No. 1 and fasten the **blue** wire to connection No. 3 of the terminal plug, as shown in Fig. 3.

## CAUSES OF TROUBLE WITH MACHINE 221-1

### **Failure to Start or Incorrect Speed**

Machine may fail to start or may run too fast or too slow due to damage after final factory inspection, improper selection of motor, or other causes as follows:

#### **Causes of Low Speed or Failure to Run**

##### **1.—Heavy or Gummed Lubricant**

If the sewing machine has not been run for some time, the lubricant may have become heavy, thereby reducing normal speed. To overcome this, run the machine unthreaded for a few minutes with the presser foot raised. If a poor grade of lubricant has been used and has become gummy, wash off all of the lubricant from the sewing machine with kerosene, dry with a clean cloth and re-lubricate with Singer Oil and Singer Motor Lubricant.

##### **2.—Too Much Pressure on the Presser Foot**

Pressure on the presser foot should be as light as possible without interfering with the feeding of the material.

##### **3.—Machine Binds**

This may be determined by turning over the balance wheel slowly by hand, in the direction for sewing. If the machine binds, do not attempt to run it, but examine all of the working parts and correct the damage if any is found. A dry machine will bind and should be lubricated, using Singer Oil and Singer Motor Lubricant. If the motor binds, be sure to fill the grease cups with Singer Motor Lubricant and run the motor for a few moments with belt removed. If this does not improve the condition, it indicates that the end covers are not properly seated or that the shaft is bent. In the latter case, the armature should be replaced.

##### **4.—Electric Current Not Turned On**

##### **5.—Loose or Broken Electrical Connections**

Examine carefully all plugs and connections in accordance with instructions on pages 8 to 14, inclusive, and make sure that there are no broken wires and that all screwed and soldered connections are tight. If the pins of the three-pin terminal fit loosely in the three-pin terminal plug, slightly spread apart the prongs of the pins (C, Fig. 13).



## **6.—Motor Not Suited for Electric Supply**

See that the voltage of the electric supply, also the frequency if it is alternating current, are within the range stamped on the motor name plate. If the motor is run on a voltage lower than that stamped on the name plate, the speed of the motor will be too slow. If the motor is run on a voltage higher than that stamped on the name plate, the speed of the motor will be too fast and cause damage. See "Singer Series 3 Motors," page 3.

## **7.—Dirty Commutator**

See that there is no carbon or grease on the commutator (see "To Inspect and Clean the Armature," page 17) and that it is smooth. The commutator can easily be cleaned with a rubber eraser. Never use anything else on a small motor commutator.

## **8.—Carbon Brushes Not Making Contact**

This may be due to brushes sticking in brush tubes, or grease on the commutator. See "To Reassemble the Motor," pages 18 and 19.

## **9.—Armature Binding**

This can be determined by rotating the motor pulley (E, Fig. 14) with the fingers, when the belt is removed from the pulley.

### **Causes of Binding:**

- a.—Motor end covers not properly seated and tightened. See "To Reassemble the Motor," pages 18 and 19.
- b.—Lack of lubrication. Grease cups may be dry.
- c.—Brush tubes rubbing on commutator. This might occur in case the brush tubes are not properly seated in the insulated bushings. See "To Remove and Replace Brush Tubes," page 18.
- d.—Armature striking field coils.

## **10.—Broken Armature Wires**

See that the fine wiring on end of armature has not been broken. See "To Inspect and Clean Armature" page 17.

## **11.—Controller Not Properly Adjusted**

See Instructions on pages 12, 13 and 14.

## To Inspect Electrical Connections of Three-Pin Terminal, Motor, Singerlight and Singerlight Switch

(SEE FIG. 2—WIRING DIAGRAM)

To inspect any of the wiring and connections at the machine, remove bottom cover plate, by first removing thumb nut in centre of bottom cover plate.

**Three-Pin Terminal**—Remove screw (B, Fig. 13), and displace the three-pin terminal and inspect the connections at the three thumb nuts (B, Fig. 4). See that the thumb nuts are screwed down firmly to ensure tight connections at the three-pin terminal. Each of the three pins is provided with a washer. See that this washer is, in each case, placed above the wire or wires before tightening the thumb nuts.

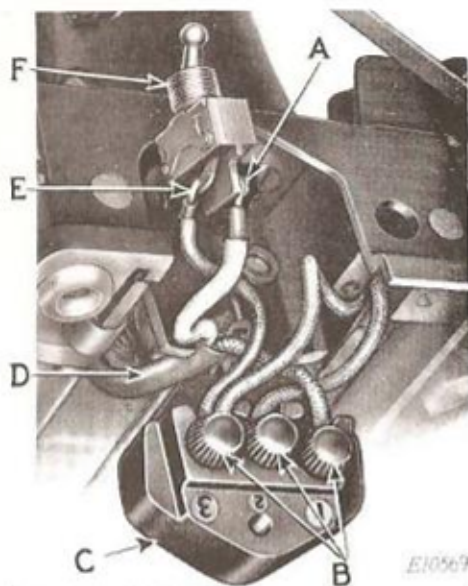

FIG. 4. WIRING, WITH THREE-PIN TERMINAL AND SINGERLIGHT SWITCH DISPLACED

**Motor**—Remove the motor in accordance with instructions on page 15. Inspect the soldered connections at the brush tubes. See "Remove Commutator End Cover," page 17, and "Remove and Replace Brush Tubes," page 18.

**Singerlight Switch**—To remove Singerlight switch, it is necessary to first displace the three-pin terminal (C, Fig. 4) in accordance with above instructions. Next unscrew and remove the knurled screw cap (J, Fig. 14) and hexagon retaining nut (H, Fig. 14) and carefully push the switch (F, Fig. 4) down through the machine bed, where connections can conveniently be inspected, as shown by Fig. 4. The **red** wire, which connects the **red** pin (No. 3) of the three-pin terminal and the Singerlight switch, is soldered at the switch as shown by (E, Fig. 4). If this connection is broken, solder the **red** wire to the lug (E) of the switch connection. The **white** wire, leading from the Singerlight switch to the Singerlight,



is connected to the switch by screw (A, Fig. 4). See that this connection is tight. When replacing the Singerlight switch, put in place the thin fibre insulation which covers the switch connections, and have the red wire soldered connection (E) toward the front side of the machine when the switch is fastened in place on the machine bed. Tighten retaining nut (H, Fig. 14) and screw cap (J, Fig. 14).

**Singerlight**—Remove screw (H, Fig. 5) and clamping plate (G, Fig. 5) to release the lead-covered cable (Singerlight leads) (D, Fig. 4). Remove screw at (P, Fig. 6), which fastens the Singerlight to the machine arm. Then draw the Singerlight from the machine, being careful not to strain or loosen the connections at the Singerlight switch and three-pin terminal. To inspect Singerlight connections, it is not necessary to completely remove the Singerlight and wiring from the machine. Have the Singerlight in the position shown by Fig. 6

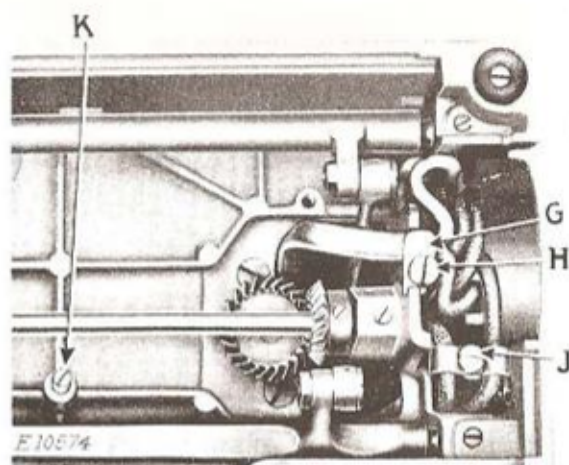

FIG. 5. MOTOR AND SINGERLIGHT LEADS

and loosen screw (M, Fig. 6) and screw (N, Fig. 6). With the left hand reach beneath the shade (O, Fig. 6) while Singerlight is in the position shown by Fig. 6, and grasp the lamp socket (Q, Fig. 7). With the right hand carefully draw the Singerlight shade (O, Fig. 6) to the right, thus removing it from the lamp socket (Q, Fig. 7) attached to the lead-covered cable. Remove the two screws (T, Fig. 7) and take off the lamp socket cap (S, Fig. 7), thus uncovering the soldered connections at the Singerlight terminal, as shown at (R, Fig. 7). If these connections are broken, they must be soldered to the terminal lugs as shown in (R, Fig. 7). In such case, remove the screw which fastens the white Singerlight wire to the switch terminal at (A, Fig. 4); also remove the thumb nut at the yellow pin (No. 1) of the three-pin terminal to disconnect the yellow Singerlight wire. Then carefully remove the lead-covered

cable (D, Fig. 4) out through the hole (L, Fig. 6) at the Singerlight seat. Observe the position of this lead-covered cable (D, Fig. 4)

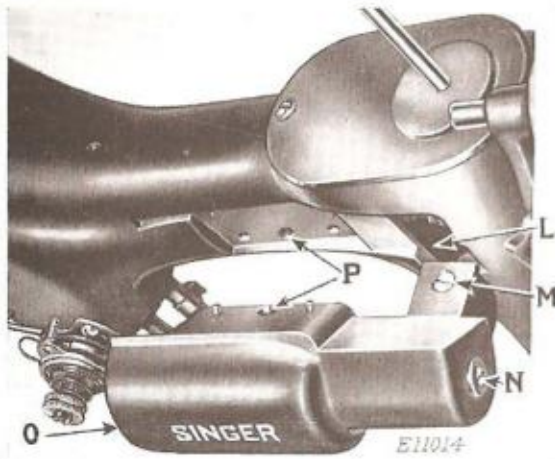

FIG. 6. SINGERLIGHT DISPLACED FROM ITS SEAT ON MACHINE ARM

before removing it, as this will serve as a guide when replacing it. This cable must be prevented from coming in contact with any moving parts of the machine.

Fasten the lamp socket cap (S, Fig. 7) to the lamp socket (Q, Fig. 7) with the two screws (T).

Put the felt washer (U, Fig. 7) on the cap (S, Fig. 7) and then place the assembled Singerlight terminal

and lamp socket in the Singerlight shade (O, Fig. 6). Tighten the two screws (M and N, Fig. 6) and fasten the assembled Singerlight to the machine arm by inserting and tightening screw at (P, Fig. 6).

Should it be necessary to replace Singerlight leads with new ones, these are furnished, lead-covered, as a unit. Order Singerlight cable (lead-covered) complete, No. 193917.

Connect the Singerlight white wire to the screw connection of the Singerlight switch, and the Singerlight yellow wire to the

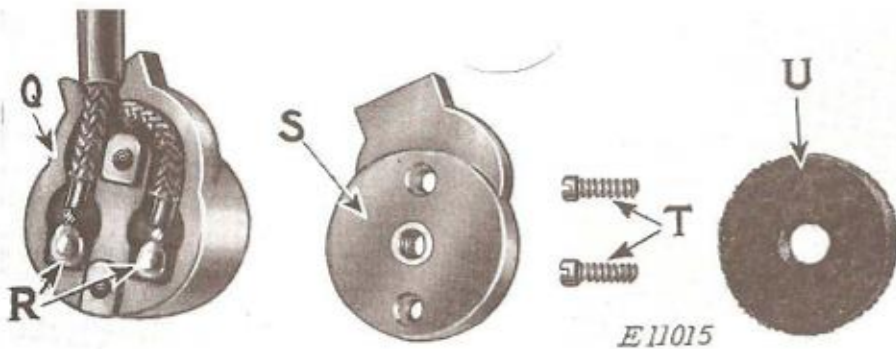

FIG. 7. SINGERLIGHT CONNECTIONS

yellow pin (No. 1) of the three-pin terminal. Secure the end of the lead covering for Singerlight cable by means of the clamping plate (G, Fig. 5) and screw (H, Fig. 5). Then replace three-pin terminal.



## Singerlight Fails to Light

This may be due to any one of the following causes:

1. Electric current not turned on.
2. Singerlight switch not turned on.
3. Loose or broken connections. See that the two insulated thumb nuts of the three-pin terminal, marked 1 and 3, respectively, Fig. 2, page 4, which fasten the Singerlight wires to the terminal posts, are firmly tightened.
4. The Singerlight bulb may be broken or burned out.

**Note** The voltage marked on the Singerlight bulb must be within the range stamped on the name plate of the electric meter installed by the local Electric Light Company.

In ordering bulbs from the factory, specify Singerlight Lamp Part No. 194120 and state the voltage of the lamp required.

## To Remove and Replace Bulb

Do not attempt to unscrew the bulb. It is of the double contact bayonet, candelabra type and does not unscrew.

To remove the bulb, press it into the socket and, at the same time, turn it in a counter-clockwise direction as far as it will go, then withdraw the bulb.

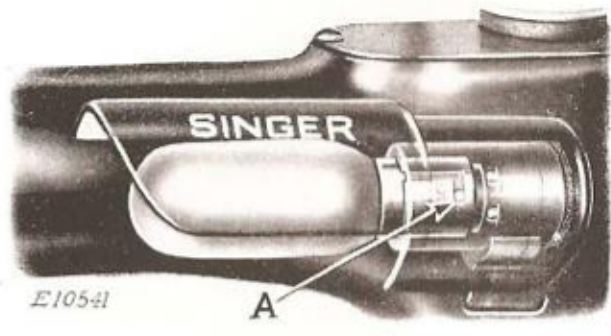

FIG. 8. REPLACING THE BULB

To insert a new bulb, press it into the socket and turn it, in a clockwise direction, until the bulb pin (A) enters the notch in the socket, as shown in Fig. 8.

## To Inspect Electrical Connections of Three-Pin Terminal Plug, Carbon Foot Controller and Electric Outlet Socket Plug

(SEE FIG. 3—WIRING DIAGRAM)

The **Three-Pin Terminal Plug**, shown in Figs. 9 and 10, has three sleeves (W, Fig. 10) which are engaged by the three pins (C, Fig. 13) when the plug is pushed into the three-pin terminal

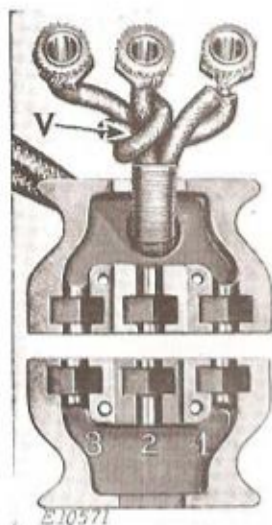

FIG. 9  
TERMINAL PLUG  
(CONNECTIONS  
REMOVED)

terminal block. Make sure that these connections are tight and that the hexagon heads of these sleeves are properly seated in the plug as shown by Fig. 10.

Note that the blue wire, from plug connection, and the black controller wire are knotted together as shown at (V, Figs. 9 and 10). This is to prevent strain or breakage in case the plug is pulled from the three-pin terminal by grasping the wires instead of the plug. Therefore the knot is placed so that it,



FIG. 10  
TERMINAL PLUG  
(CONNECTIONS  
IN PLACE)

instead of the connections, bears the strain when the plug is drawn from the terminal.

**Electric Outlet Plug**—See that the wires are closely looped about the screw connections, and that the screws are firmly tightened.

### Singer Carbon Foot Controller

The Singer foot controller affords complete control of the motor; starting it, operating it at various speeds and stopping it promptly when desired. Should it fail to satisfactorily perform any of these duties, the trouble may be located by the following procedure.

#### 1.—Motor Fails to Start

Operate the pedal of the foot controller to make sure that the mechanism does not bind. Remove the cover from the controller unit as instructed in paragraph 3, page 13, and inspect the wires and connections at (C, Fig. 11).

## 2.—Motor Fails to Operate at All Speeds

### Emergency Adjustment of Carbon Resistance Unit

(SEE FIG. 11)

All carbon resistance units, after mounting upon the controller mechanism, are carefully adjusted at the factory and this adjustment cannot change unless some part of the mechanism is bent or broken.

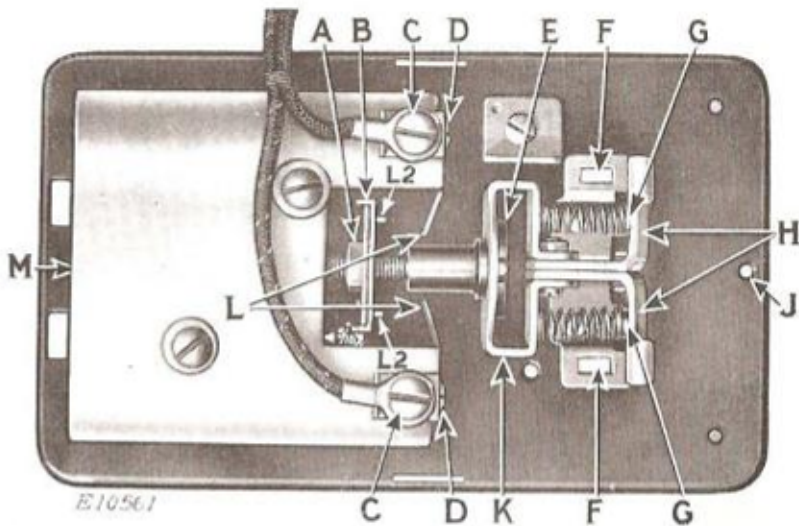

FIG. 11. EMERGENCY ADJUSTMENT OF CARBON CONTROLLER

If, however, the adjustment has been disturbed or it has been found necessary to substitute a new unit, it should be adjusted as follows:

Take out the screw at (J, Figs. 11 and 12) and remove foot controller cover, by gently lifting up, and pushing it toward the rear.

(a)—With the bell crank (H, Fig. 11) at the “off” position against the posts (G) of the spring bracket, the face of the bakelite strip, between nut (A) and cross slide (B), should be  $\frac{5}{16}$  inch from the flat face of the porcelain as shown by Fig. 11. If the distance is not  $\frac{5}{16}$  inch, release the insulated nut (E) from its seat by pushing on the end of the pull rod at (M) and turn the nut (E) until the correct adjustment is obtained. Be sure that the nut (E) seats in the yoke (K).

Do not disturb the adjustment of nut (A).



(b)—Move the mechanism to full speed position by pressing down the bell crank (H) as far as it will go. At this position, the points (L2) of the cross slide (B) should make contact with both short-circuiting strips (L) and should bend them backward about  $\frac{1}{32}$  inch. If this contact is too heavy, the strips will be bent or broken. The strips should, therefore, be bent until they make positive but not heavy contact with the cross slide points (L2) at the full speed position.

(c)—If the short-circuiting strips 193384 (L) are found to be broken, they may be replaced after removing the screws (D). Adjust as instructed under (b).

### 3.—Motor Fails to Stop

See that the bell crank (H) is at the stop position against the two spring bracket posts (G) and that the insulated nut (E) is properly seated in the yoke (K). Check the controller adjustment as explained under part 2.

When replacing the foot controller cover, put a small quantity of Singer Motor Lubricant on the controller pedal arms (N,

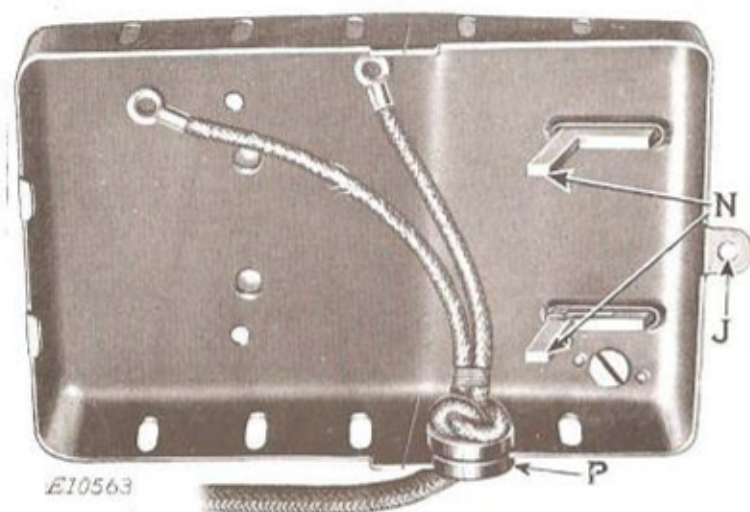

FIG. 12. VIEW OF INSIDE OF CONTROLLER COVER  
(LEADS DISCONNECTED)

Fig. 12) and insert them through the two slots (F, Fig. 11) in the spring bracket. Also put the bushing (P, Fig. 12) in place in the cut-out in the side of the foot controller cover, as shown by Fig. 12.

When the cover is properly in place, insert and tighten screw at (J, Figs. 11 and 12).

### To Remove the Motor from the Machine

Remove bottom cover plate. Remove motor belt. Take out screw (B, Fig. 13) which fastens the three-pin terminal to the

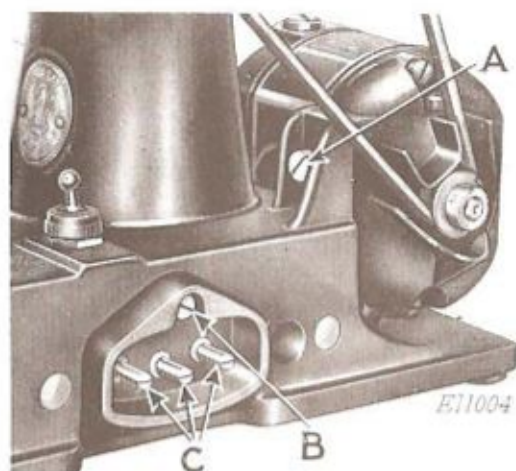

FIG. 13. SHOWING SERIES 3 MOTOR AND THREE-PIN TERMINAL IN PLACE ON MACHINE NO. 221-1

machine. Remove the insulated thumb nuts from terminal pins 2 and 3 and disconnect the black motor lead and the red motor lead from these pins. Loosen the screw (J, Fig. 5) and release

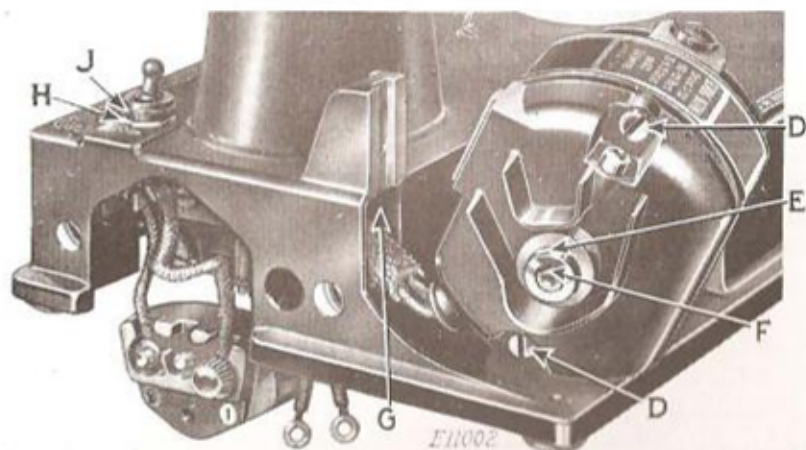

FIG. 14. MOTOR LEADS BEING WITHDRAWN FROM MACHINE

the motor leads from the clip. Then take out screw (A, Fig. 13) which fastens the motor to the bracket and remove the motor, drawing the leads out through the hole (G, Fig. 14).

### To Disassemble the Motor

**Remove Pulley End Cover**—Loosen screw (E, Fig. 14) in the hub of the belt pulley of the motor and slide the pulley off the armature shaft. Take out the two screws (D, Fig. 14). Slip the insulating tube from the motor leads and carefully pull the pulley

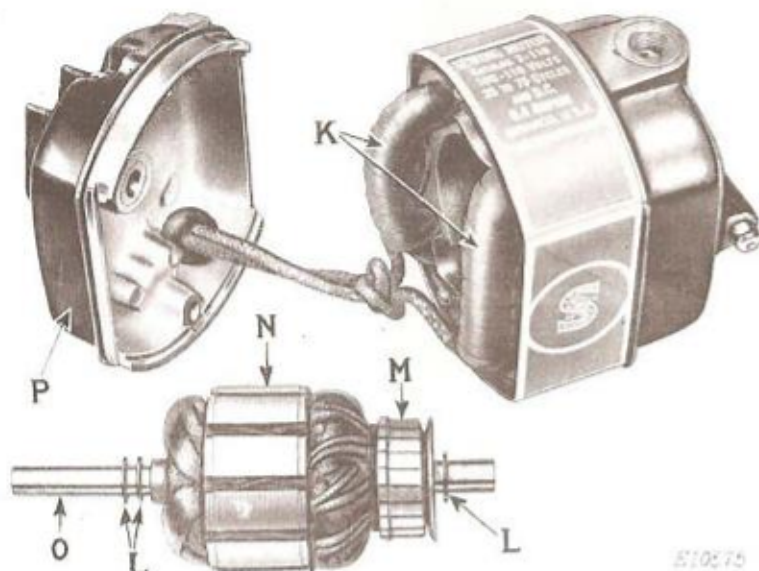

FIG. 15. SERIES 3 MOTOR WITH PULLEY END COVER AND ARMATURE REMOVED

end cover (P, Fig. 15) from the motor as shown by Fig. 15. Be careful not to lose the fibre washers on the armature shaft. It is not necessary to pull the motor leads through the pulley end cover. With the cover drawn to the ends of the leads, as shown in Fig. 15, this end of the motor is entirely accessible.

**Remove the Brushes**—Remove the two screwcaps (W, Fig. 17) which retain the brush springs (X, Fig. 17) and brushes (Y, Fig. 17), at the same time preventing the brush springs from springing out of the screw holes. In case the brush springs do not protrude from the screw holes, when the caps are removed, turn the motor so that first one and then the other of the two brush tubes is facing downward so that the brushes can drop out. If the brushes do not readily drop out of the brush tubes, a slight tapping with the fingers, while holding downward first one and then the other, will cause the brushes and brush springs to leave the brush tubes. If the brushes are stuck in the brush tubes, they may be pushed out from the inside when the commutator end cover is removed. It is advisable to mark the brushes at (Z1 and Z2, Fig. 17), thereby making sure that they will be replaced in the same relative position as they were before removal.



**Remove Commutator End Cover**—After the removal of the brushes, the commutator end cover (U, Fig. 16) should be taken off carefully so that the connections (T, Fig. 16) are not loosened

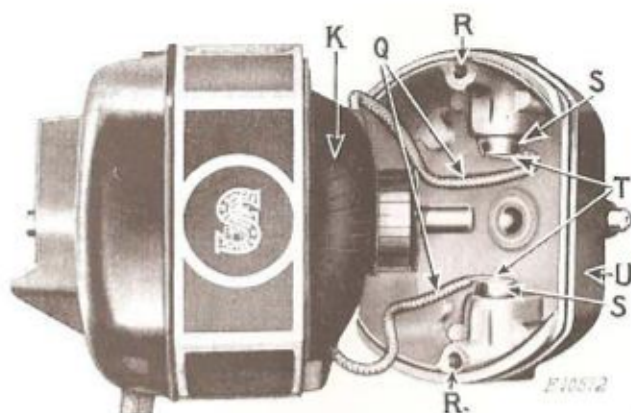

FIG. 16. SERIES 3 MOTOR WITH COMMUTATOR END COVER REMOVED

or broken. The wires (Q) are sufficiently long to make the inside of the commutator end cover and that side of the field wiring easily accessible when the cover is removed as shown in Fig. 16.

**Remove the Armature**—With the end covers and the brushes removed, as shown by Figs. 15 and 16, grasp the end of the armature shaft, preferably the pulley end of the shaft (O, Fig. 15) and draw out the armature. In case the armature is not readily withdrawn from the pulley end of the motor, withdraw from the commutator end, being very careful, in holding aside that end cover, not to strain the soldered connections (T, Fig. 16). If the armature can not readily be withdrawn from either end, it is because the field coils (K, Figs. 15 and 16) are bent over the armature. In such case, do not force the withdrawal of the armature, but inspect and clean it while it is in place. With the end covers removed, both ends of the armature are accessible even while in place in the motor.

**Inspect and Clean the Armature**—Carefully inspect the armature winding and make sure that the enamel insulation on the winding is not damaged. Damage to the enamel insulation will prevent the proper operation of the motor. Also see if any wires are broken, bare or burned, in which case return the complete motor to the factory to be repaired. If the wiring is found undamaged in any way, before reassembling the motor, clean the commutator (M, Fig. 15) with a dry, clean cloth. If it is impossible to get the commutator bright by this means, use an ordinary rubber eraser. **Never use anything else on a small motor commutator.**

**Inspect Wire Connections to Brush Tubes**—Examine both wire connections (T, Fig. 16) at brush tubes. If there are any loose strands of wire, they should be cut off. Make certain that the wires are firmly soldered to the lugs (T).

**Clean Brushes and Brush Tubes**—Thoroughly clean the carbon brushes (Y, Fig. 17), inner walls of brush tubes and inside of end covers, with a clean, dry cloth.

**Remove and Replace Brush Tubes**—After the brushes and brush tubes have been cleaned, the brushes should slide freely in the brush tubes. If they do not, the brush tubes should be replaced by new ones, being sure that they are installed the same as the old tubes, and that field leads are properly soldered to the new tubes.

**Remove and Replace Insulating Bushings**—If the threads in the insulating bushings (S, Fig. 16) and on the screw caps (W, Fig. 17) become stripped, these parts should be replaced by



FIG. 17. BRUSHES READY FOR REPLACEMENT

new ones. Loosen the screws at (R, Fig. 16) to release the bushings (S). When the new bushings are in place, tighten the screws (R).

**To Reassemble the Motor**—Put the commutator end cover in place on the motor frame. To make sure that the wires from the field coils to the brush tubes are safely positioned after the commutator end cover is in place on the motor, observe the wires through the field coils from the pulley end of the motor while the pulley end cover and the armature are removed. If the wires are not properly placed (to avoid contact with the armature or commutator) they can be reached through the field coils.

Then carefully replace the armature through the field core and insert the end of armature shaft into the shaft bearing in the commutator end cover (U, Fig. 16). The inwardly projecting



lubricating wick must be pushed back into the lubricating wick tube before passing the shaft through the bearing. Do not displace the fibre washers (L, Fig. 15) which are on both ends of the armature shaft to prevent end play. Replace the pulley end cover (P, Fig. 15), first pushing the lubricating wick back into the lubricating wick tube before the shaft enters the bearing. Pull on leads, to make sure they do not touch armature. Insert the two screws (D, Fig. 14) and tighten them, after making sure that the end covers are properly seated on the motor frame. The end covers must be fitted solidly and accurately to the motor body to ensure perfect alignment of the armature shaft bearings. Otherwise the armature will not run freely. Turn armature shaft with hand to ascertain that it turns freely and does not rub against anything. Insert the brushes, making certain that their concave ends (Z1 and Z2, Fig. 17) conform to the convex surface of the commutator, being sure that the markings at (Z1 and Z2, Fig. 17)—as described on page 16 and indicated on page 18—face you. Hold the end of the brush spring and tap the brush against the commutator until contact is clearly heard. Then insert and tighten the two screw caps (W, Fig. 17). Put belt around pulley and replace the pulley on armature shaft, tightening screw (E, Fig. 14) on flat side (F, Fig. 14) of shaft.

**To Replace the Motor**—Pass the motor leads and insulating cable down through hole (G, Fig. 14). Secure the motor leads at clip (J, Fig. 5) and connect the solid black lead to terminal No. 2 and the red lead to terminal No. 3; then tighten the two insulated thumb nuts at these terminals. Fasten the three-pin terminal in position by means of the screw (B, Fig. 13). Fasten the motor to the bracket by means of screw (A, Fig. 13), and adjust the belt tension as instructed in the following paragraph.

**To Adjust Belt Tension**—Loosen screw (A, Fig. 13) which fastens the motor to the machine bed. If the belt is too tight, slide the motor upward on the motor bracket. If the belt is too loose, slide the motor downward. When the belt is just tight enough to drive the machine, without belt slippage, tighten screw (A, Fig. 13).

**To Lubricate the Motor**—Insert tip of the lubricant tube in the hole of each of the two grease cups on the motor and squeeze a small amount of lubricant into each grease cup.

**Never, under any circumstances, use oil in the grease cups or on any part of the motor.** Grease will remain in the bearings, but oil works its way onto the commutator and brushes, causing most of the troubles experienced with small motors, such as slow speed, failure to start, overheating, smoking, etc. These troubles may be remedied by removing the oil from the commutator, brushes and inner walls of the brush tubes.



### To Remove and Replace Throat Plate

Turn the balance wheel over toward you until the needle moves up to its highest point, and remove the presser foot. Take out the two screws which fasten the throat plate to the machine bed.

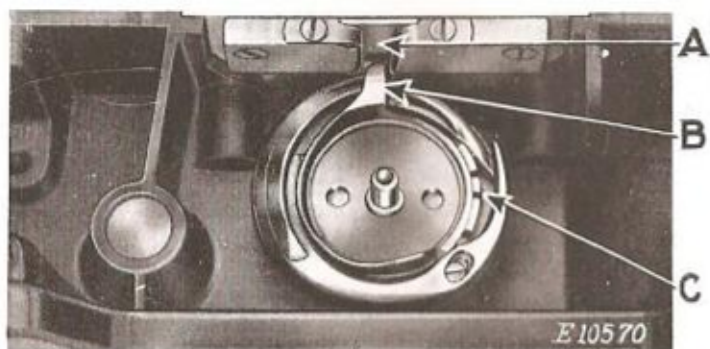

FIG. 18. BOBBIN CASE BASE POSITIONING FINGER IN PLACE IN POSITION PLATE

When replacing the throat plate, be sure that the positioning finger (B, Fig. 18) of the bobbin case base is in the notch of the position plate (A, Fig. 18), attached by Fig. 18.

### To Remove and Replace Hinged Bed Extension

When it is desired to take off the hinged bed extension (D, Fig. 19), remove the two screws (G, Fig. 19) which attach the hinged extension to the machine bed.

Particular attention is called to the two washers with which each of the two screws (G) is provided. The black spring washer (F) should be placed with its convex side against the screw head, and the flat white washer (E) is next placed on the screw. When replacing the hinged bed extension, tighten the two screws (G, Fig. 19) so that the hinged extension will remain in a raised position when desired.

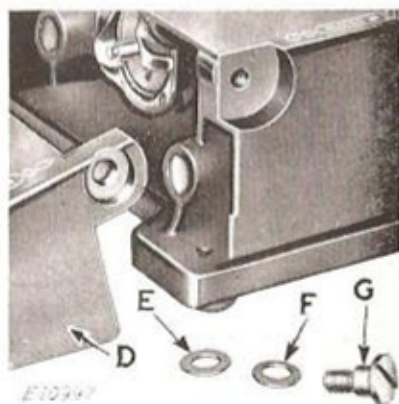

FIG. 19. SHOWING HINGED BED EXTENSION REMOVED

## To Time the Rotary Sewing Hook

Remove the face plate, presser foot, throat plate and feed dog. Place a new needle in the needle bar, pushing it up into the needle bar as far as it will go.

The needle bar has two timing marks near its upper end. Turn the balance wheel toward you until the **lower timing mark** on the needle bar is centred with the lower end of the needle bar bushing when the needle bar is on its upward stroke, as shown at (X, Fig. 20). When the needle bar is in this position, the **point of the sewing hook** should be at the **centre of the needle**, as shown at (Z, Fig. 20), if the hook is correctly timed.

In case the hook is not correctly timed, turn the machine over on its rear side and remove the bottom cover plate after taking off the thumb nut which holds the bottom cover plate in place.

Loosen the two set screws (C, Fig. 25) in the gear on the right hand end of the hook shaft, and turn the hook until its point is in proper relation to the needle as explained above. Then tighten the two screws (C, Fig. 25), making sure that the gear is pushed against the bushing (A, Fig. 25) at the right hand end of the shaft, and that the slightly raised portion or "boss", on one side of the collar and counterbalance, (H, Fig. 25), is against the bushing at (J, Fig. 25) to prevent end play.

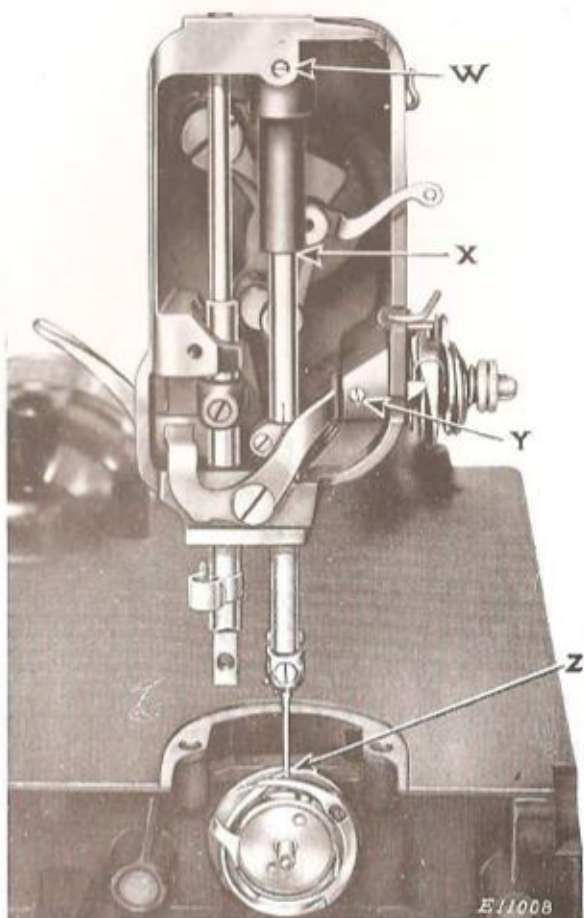

FIG. 20. TIMING ROTARY SEWING HOOK



### To Set the Needle Bar at the Correct Height

With the hook correctly timed, as instructed on page 21, turn the balance wheel toward you until the needle bar reaches its lowest point. With the needle bar in this position, the **upper timing mark** should be centred with the lower end of the needle bar bushing as shown at (F, Fig. 21). If the needle bar is not set at the correct height, loosen screw (D, Fig. 21) and move the needle bar up or down until the **upper timing mark** is centred with the lower end of the needle bar bushing as shown at (F, Fig. 21). Then securely tighten screw (D).

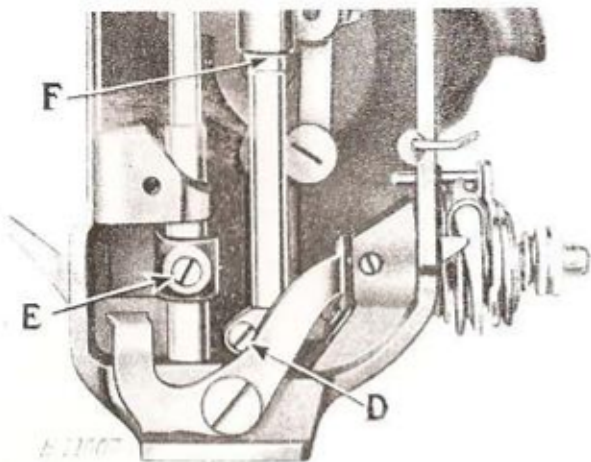

FIG. 21. NEEDLE BAR SET AT CORRECT HEIGHT

The needle bar bushing is accurately set at the factory, and its position should not be disturbed. If its position has been disturbed, turn the balance wheel toward you until the point of the hook is at the centre of the needle and approximately  $\frac{1}{16}$  inch above the top of the eye of the needle. Loosen set screw (W, Fig. 20) and move the bushing up or down until its lower end centres with the **lower timing mark** at (X, Fig. 20). Then tighten set screw (W, Fig. 20).

### To Remove and Replace Sewing Hook and Bobbin Case Base



FIG. 22  
REAR VIEW OF ROTARY  
HOOK

Remove face plate, presser foot, throat plate, feed dog and bottom cover plate. Loosen the two screws (G, Fig. 22) in the hub of the rotary hook. Remove the rotary hook from the shaft. To remove the bobbin case base (M, Figs. 23 and 24), take out



FIG. 23  
FRONT VIEW OF ROTARY  
HOOK

screw (H, Figs. 22 and 24) and spring (J, Figs. 22 and 24) from



the rear side of the hook, and take out screw (K, Figs. 23 and 24) from the front side of the hook. This permits the removal of gib

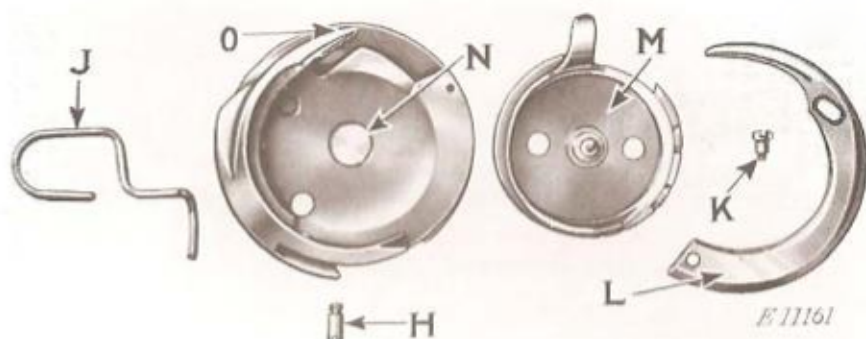

FIG. 24. ROTARY SEWING HOOK DISASSEMBLED

(L, Figs. 23 and 24), after which the bobbin case base (M, Figs. 23 and 24) can be lifted from the face of the hook. To reassemble the rotary sewing hook, put the bobbin case base (M) in its seat in the rotary hook. Put the gib (L) in the open end slot which forms its seat in the rotary hook. Replace the screw (H) and spring (J) on the rear side of the hook, and screw (K) on the front side of the hook.

Turn the balance wheel toward you until the needle bar, on its downward stroke, reaches a position approximately midway of the limits of its stroke, and the "flat" on the end of the shaft faces downward where it will be accessible through the opening (M, Fig. 25). Next place the rotary hook on the shaft, with the hook point (O, Figs. 23 and 24) at the same side of the shaft as the "flat", so that the hub screw (G, Fig. 22) nearest to the hook point (O, Figs. 23 and 24) engages this "flat", then, while keeping the hub of the hook against the shaft bushing at (L, Fig. 25) tighten, first, the screw (G, Fig. 22) which engages the "flat" and then tighten the other of the two screws (G, Fig. 22).

If the rotary sewing hook requires timing, follow the instructions on page 21.

### To Remove and Replace the Rotary Hook Shaft

Take off the bottom cover plate, and remove the rotary sewing hook and the needle. Loosen the screw (H, Fig. 25) in the collar and counterbalance so that it slides freely on the shaft. Loosen the two screws in gear (C, Fig. 25) so that the shaft can be pushed through it. Remove screw (B, Fig. 13) and push aside the three-pin terminal, being careful not to strain the electrical connections. Use the new shaft (E, Fig. 25) to push the old shaft (G, Fig. 25) through from the right hand end of the machine and out at the

hook end, as shown by Fig. 25. Insert the new shaft so that the end with the two "flats" (F and D, Fig. 25) for the rotary hook screw and for the collar and counterbalance screw, respectively is at the left as illustrated in Fig. 25.

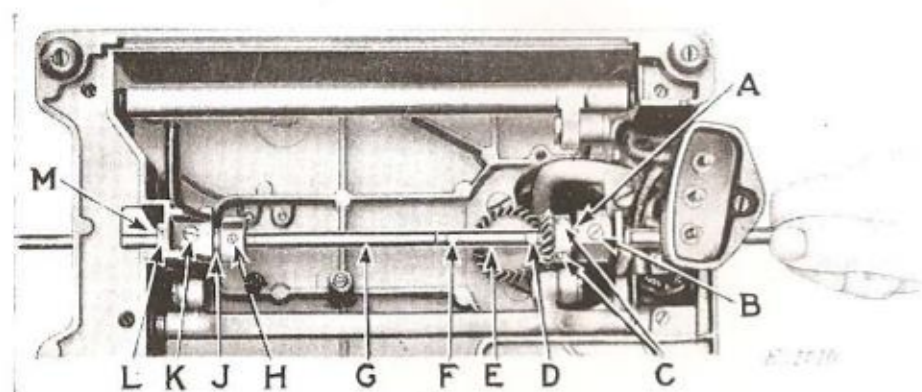

FIG. 25. REPLACING ROTARY SEWING HOOK SHAFT

Shaft replacement should be made without disengaging the teeth of the gears at (C, Fig. 25). The method covered by the foregoing instructions will keep these gears in mesh during the replacement of the shaft.

**When the new shaft is in place, do not tighten any of the screws until the correct location of the shaft with relation to the rotary sewing hook has been determined.** The shaft should be set so that its left end is flush with the face (N, Fig. 24) of the rotary hook when the hub of the hook is against the shaft bushing, and the screw (G, Fig. 22) in the hub of the hook, and nearest to the point of the hook (O, Figs. 23 and 24) engages the "flat" of the shaft.

To determine the proper position of the shaft in the hook, it is necessary to remove the bobbin case base, as instructed on pages 22 and 23. It is very important to have the end of the hook shaft exactly flush, or slightly less than flush, with the sewing hook face, because if the shaft is permitted to protrude, even very slightly beyond the face of the rotary sewing hook, the machine will not sew. Reassemble the rotary sewing hook as instructed on page 23. Place the hub of the rotary sewing hook against the shaft bushing at (L, Fig. 25). Then tighten the screw (G, Fig. 22) nearest to the point of the hook (O, Figs. 23 and 24), against the "flat" of the shaft. After tightening this one, then tighten the one on the other side of the hub on the side opposite the point of the hook (O, Figs. 23 and 24). Tighten the two screws (C, Fig. 25) while the gear is against the shaft bushing



(A, Fig. 25) at the right hand end of the shaft. Tighten the screw (H, Fig. 25) in the collar and counterbalance, making certain that the slightly raised portion or "boss" of the collar and counterbalance is against the bushing as indicated at (J, Fig. 25) to prevent shaft end play. Also make sure that the screw (H) engages the "flat" (D, Fig. 25) on the shaft.

### Latest Type Rotary Sewing Hook, Collar and Counterbalance and Rotary Sewing Hook Shaft

The latest type rotary Sewing Hook, Figs. 26, 27 and 28, differs from the previous type of hook (shown and described on



FIG. 26. FRONT VIEW OF NEW SEWING HOOK

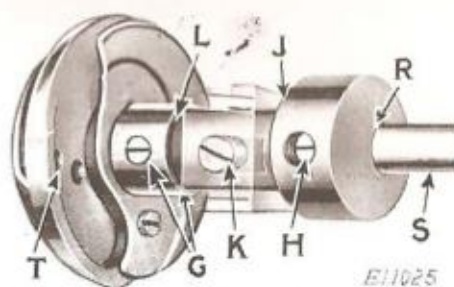

FIG. 27. REAR VIEW OF NEW SEWING HOOK ON NEW SHAFT

pages 22 and 23) in that the new hook is provided with a non-yielding gib (O, Figs. 26 and 28) and is therefore not provided with the spring (J, Figs. 22 and 24). An important advantage of the new type hook is that it is not necessary to remove the hook from the shaft and disassemble it in order to remove the bobbin case base.

**To Remove and Replace Bobbin Case Base**—Remove the throat plate and take out screw (P, Fig. 26) so that the gib (O, Fig. 28) can be displaced as shown in Fig. 28. Turn the bobbin case base so that the small point (U, Fig. 28) on the bobbin case base is beneath the point of the sewing hook, as shown in Fig. 28, and take out the bobbin case base (Q, Fig. 28). To replace bobbin case base, reverse the operation.

To entirely remove the gib from the sewing hook, remove screw (P, Fig. 26) from the front side of the hook, and screw (T, Fig. 27) from the rear side. The gib (O, Fig. 26) can then be taken from the sewing hook. To replace the gib, reverse the operation.

The latest type hook shaft is provided with a locating mark (R, Fig. 27), and its advantage is that it is not necessary to disassemble the rotary hook (see page 24) to determine the proper location of the shaft in the hook.



**To Remove and Replace Latest Type Rotary Hook Shaft—**  
See Fig. 25 which will serve to illustrate the removal and replacement of the latest type shaft

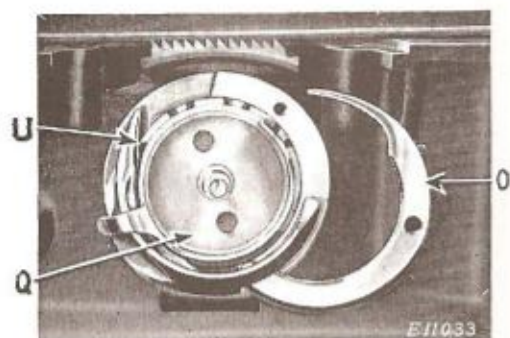

FIG. 28. GIB TURNED ASIDE FOR REMOVAL OF BOBBIN CASE BASE

of the latest type shaft (S, Fig. 27). The instructions for removing and replacing this shaft are the same as for the previous type shaft, pages 23, 24 and 25, except that the correct location of the shaft, relative to the hook, is determined by centering the right hand side of collar and counterbalance (H, Fig. 27) with the locating mark (R, Fig. 27).

Insert the shaft into its bearings in the machine and through the gear (C, Fig. 25) and collar and counterbalance (H, Fig. 27), place the collar and counterbalance (H, Fig. 27), with the slightly raised portion or "boss", against the bushing at (J, Fig. 27) and position the shaft so that its locating mark (R, Fig. 27) centres with the right hand side of the collar and counterbalance, as shown in Fig. 27, and so that the screw (H, Fig. 27) engages the "flat" on the shaft, then tighten screw (H). Place the rotary hook on the shaft, with the hook point at the same side of the shaft as the "flat", so that the hub screw (G, Fig. 27), nearest to the hook point, engages this "flat", then, while keeping the hub of the hook against the bushing at (L, Fig. 27), tighten first the screw (G, Fig. 27) which engages the "flat" and then tighten the screw on the opposite side of the hub. Have the gear at the right hand end of the shaft, against the bushing at (A, Fig. 25) and tighten the two screws (C, Fig. 25). Fig. 27 shows latest type hook and collar and counterbalance on the latest type shaft, and shows these parts properly assembled.

**Note**—The new shaft, sewing hook and collar and counterbalance are not individually interchangeable with similar previous type parts, but are interchangeable with similar previous type parts as a unit consisting of these three parts.

### **To Adjust Position of Point of Rotary Sewing Hook with Relation to Side of Needle**

Before the machine leaves the factory, bushing (L and J, Figs. 25 and 27) is set to bring the hook point in proper relation to the

side of the needle. Should this adjustment have been disturbed, loosen set screw (K, Figs. 25 and 27) and move the bushing (L and J, Figs. 25 and 27) to obtain this adjustment. Then tighten set screw (K, Figs. 25 and 27).

### To Raise or Lower the Feed Dog

When the feed dog is raised to its highest point by the feed connecting rod, the top of the teeth should be not more than  $\frac{3}{64}$  inch above the top surface of the throat plate. At this height, slightly less than the full depth of the teeth will protrude from the feed dog slots in the throat plate.

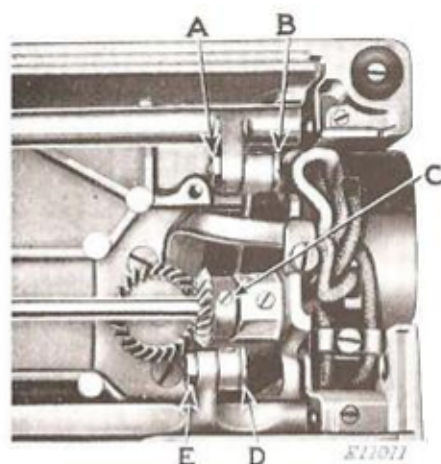

FIG. 29. FEED DOG ADJUSTMENT

When it is necessary to raise or lower the feed dog, remove the bottom cover plate and loosen the nut (E, Fig. 29) on the end of the feed lifting eccentric screw (D, Fig. 29). Turn the eccentric screw (D) until the high throw of the eccentric is toward the rotary hook shaft gear (C, Fig. 29). When the eccentric screw (D) is in this position, the top of the feed dog teeth will be at the correct height above the throat plate. Be careful not to adjust the feed dog low enough to strike the hook when the feed is in reverse and when the longest stitch is being used. Then securely tighten nut (E, Fig. 29).

### To Adjust the Position of the Feed Dog Lengthwise in the Feed Dog Slots in the Throat Plate

The feed dog should be positioned in the slots of the throat plate so that it will not come in contact with the throat plate at either end of the slots during its travel. If the feed dog is not correctly positioned, remove the bottom cover plate. Loosen the nut (A, Fig. 29) on the end of the eccentric screw (B, Fig. 29) and turn the screw so that the centre row of teeth will be close to the end of the feed dog slot nearest the needle hole in the throat plate, but not close enough to strike the end of the slot. The eccentric



screw (B, Fig. 29) is in correct position when the high throw of the eccentric is upward and away from the gear (C, Fig. 29) on the hook shaft.

### Timing of the Feeding Mechanism

The feeding mechanism is accurately timed and permanently set before the machine leaves the factory, and requires no adjustment.

#### To Adjust the Presser Bar

With the presser bar lifter raised, there should be a clearance of about  $\frac{5}{16}$  inch between the presser foot and the throat plate. With the presser bar lowered, the presser foot should be aligned with the feed dog.

In case the presser bar is not set as instructed, remove the face plate and raise the presser bar lifter. Then loosen presser bar bracket screw (E, Fig. 21) and raise or lower the presser bar until proper height is obtained, making sure that the presser foot is correctly aligned with the feed dog. Then securely tighten screw (E, Fig. 21).

#### To Adjust the Bobbin Winder

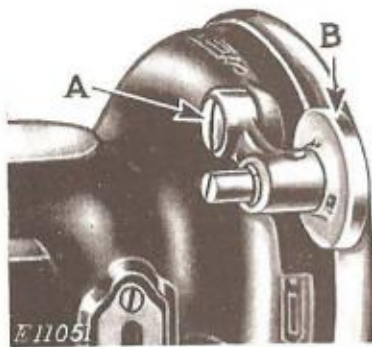

FIG. 30. BOBBIN WINDER

If the pressure of the bobbin winder pulley against the belt on the hub of the balance wheel is insufficient for winding the bobbin, tighten the adjusting screw (A, Fig. 30) sufficiently to hold the pulley (B, Fig. 30) against the belt. The pressure of the bobbin winder pulley against the belt should be just enough to operate the bobbin winder.

#### To Adjust Bobbin Winder Tension Bracket

If the thread does not wind evenly on the bobbin, loosen the screw (C, Fig. 31) which secures the bobbin winder tension bracket (D, Fig. 31), and move the bracket to the right or to the left as required. Then securely tighten screw (C).

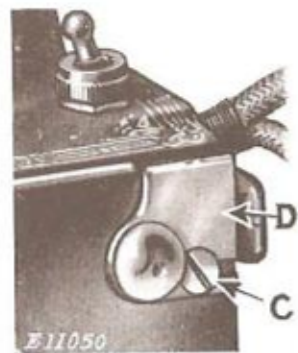

FIG. 31. BOBBIN WINDER TENSION BRACKET



### To Regulate the Thread Take-up Spring

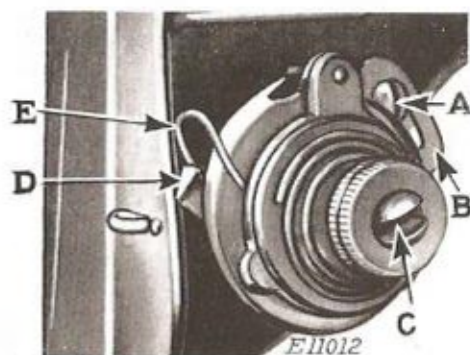

FIG. 32. THREAD TAKE-UP SPRING

The thread take-up spring (E, Fig. 32) should be set so that when the eye of the needle reaches the goods on the downward stroke of the needle bar, the spring will be through acting and will rest against the stop (D, Fig. 32) on the thread take-up spring regulator plate (B, Fig. 32). If the thread take-up spring is not correctly

regulated, as instructed, loosen screw (A, Fig. 32) and turn the spring regulator plate (B) to the right to decrease thread take-up spring movement, or to the left to increase the spring movement. When spring (E) is correctly regulated, securely tighten screw (A).

### To Adjust Tension of Thread Take-up Spring

Remove the face plate and loosen set screw (Y, Fig. 20). Turn the tension stud (C, Fig. 32) clockwise to decrease the tension, or counter-clockwise to increase the tension. The tension should be just enough to take up the slack of the needle thread until the eye of the needle reaches the goods in its descent. When the correct tension is obtained, tighten set screw (Y, Fig. 20).

### To Adjust Arm Shaft End Play

To make allowance for expansion, the correct amount of end play, for the arm shaft, is provided by adjustment before the

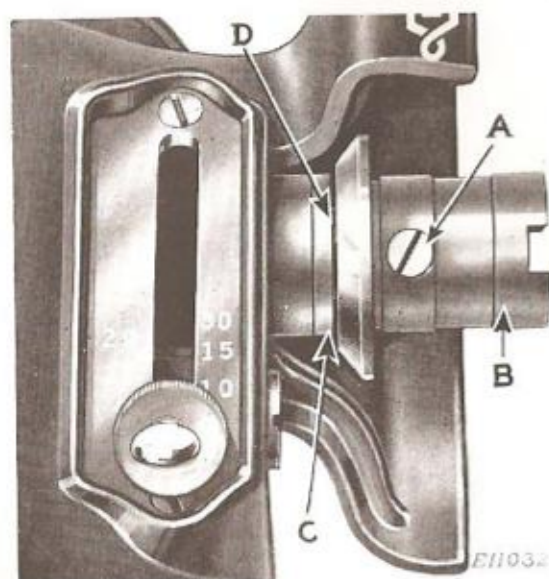

FIG. 33. ADJUSTMENT FOR SHAFT END PLAY

machine leaves the factory. In case this adjustment has been disturbed, remove the balance wheel from the machine to uncover the balance wheel bushing (B, Fig. 33). Loosen screw (A, Fig. 33) and move the balance wheel bushing (B) slightly away from the arm shaft bronze bushing (C, Fig. 33), as indicated by (D, Fig. 33). Then insert at (D) an ordinary sheet of note paper and bring balance wheel bushing (B) back against the paper, thus providing the necessary end play. Tighten screw (A), remove the sheet of paper and replace the balance wheel.

## To Oil the Machine

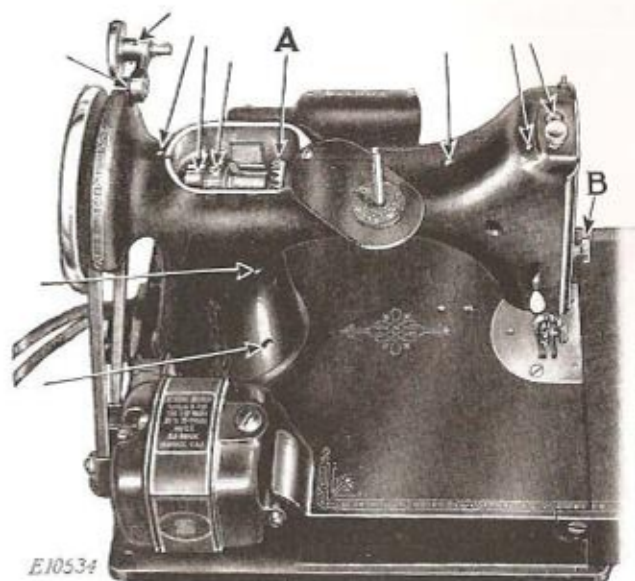

FIG. 34. REAR VIEW, SHOWING OILING POINTS

Turn back the cover at the top of the machine, after loosening the cover screw, and oil the moving parts inside the arm as indicated in Fig. 34, and occasionally apply a small quantity of Singer Motor Lubricant to the teeth of the gear (A, Fig. 34), then replace the cover and tighten the cover screw.

Take out the face plate thumb screw (B, Fig. 34) and remove the face plate. Put one drop of oil into each of the oil holes and joints thus uncovered, as shown in Fig. 35, then replace the face plate and thumb screw.

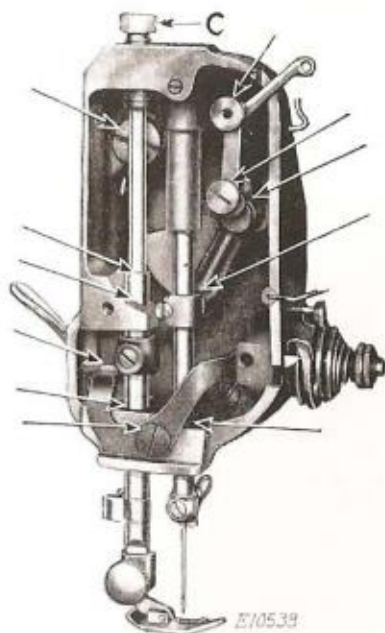

FIG. 35. END VIEW, SHOWING OILING POINTS

To ensure easy running, the machine requires oiling and if used continuously it should be oiled each day. With moderate use, an occasional oiling is sufficient. Oil should be applied at each of the places shown by arrows in Figs. 34, 35 and 36. One drop of oil at each point is sufficient. Oil holes are provided in the machine for bearings which cannot be directly reached.

Turn back the cover at the top of the machine, after loosening



**To Oil the Hook Mechanism,** occasionally apply a drop of oil at the hook bearing indicated by C, in Fig. 18.

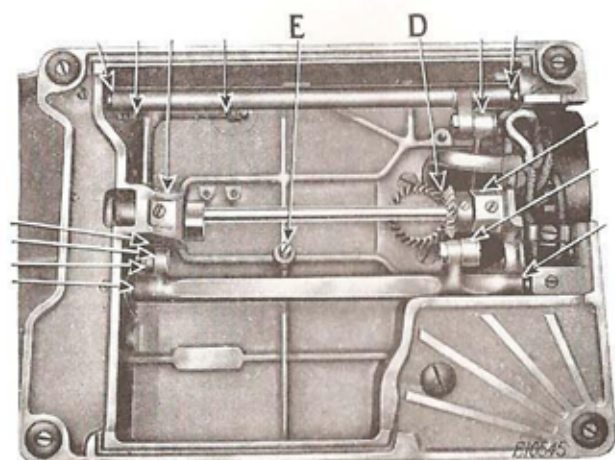

FIG. 36. OILING POINTS IN BASE OF MACHINE

To reach the parts underneath the bed of the machine, turn the machine over on its back. Remove the thumb nut from the screw (E, Fig. 36) at the centre of the large cover plate underneath the bed of the machine and remove the cover plate. Apply oil to the oil holes and bearings indicated by the arrows in Fig. 36, and occasionally apply a small quantity of Singer Motor Lubricant to the teeth of the gears (D, Fig. 36), then replace the bed cover plate and fasten it as before with the thumb nut, being careful not to turn the thumb nut too tightly.